



## Introduction

### Roller idler frames

Idler frames are metal structures which support and help align the rollers.

#### IDLER FRAME SELECTION

Idler frame selection is based on belt width and roller arrangement in relation to the load capacity of the conveyor.

Based on the type of load and speed requirements, the MEDIUM or HEAVY model is chosen, both of which are manufactured with S 235 JR structural quality.

#### SHAPE AND DIMENSIONS

Idler frames are designed according to DIN 22107, ISO 1537 and CEMA standards, taking into account the requirements and needs of the customer.

There are three main groups:

- Upper carrying
- Bottom / Return
- Self-aligning

Idler frames are designed so they will not accumulate debris or pollutants in order to avoid corrosion. This also prevents debris and pollutants from coming into contact with the rollers, thus avoiding corrosion due to friction with the conveyor belt. Energy consumption is then reduced while running the conveyor belt.

#### PROTECTIVE COATINGS

Idler frames are coated with a rust-proof primer and the following coatings can be custom ordered:

- Galvanised
- Zinc plated
- Painted

# IDLER

TROUGH

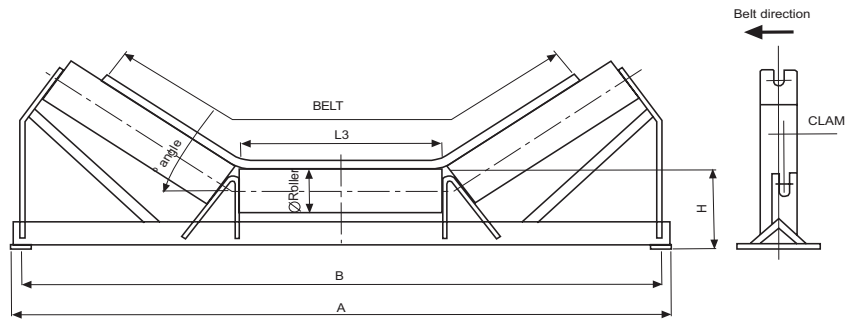

UPPER V

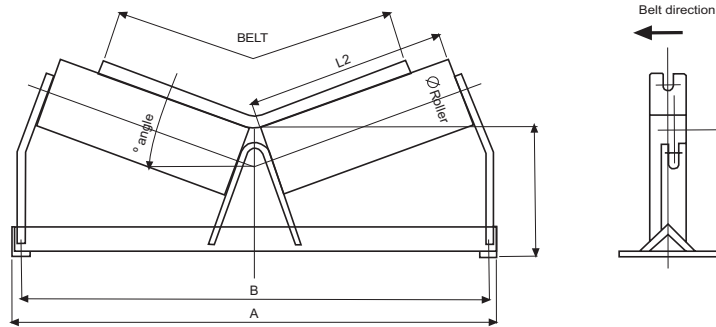

SELF-ALIGNING

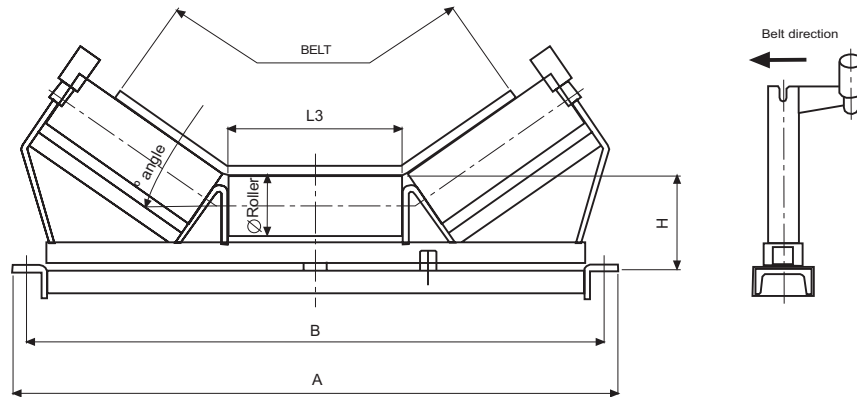

RETRACTABLE

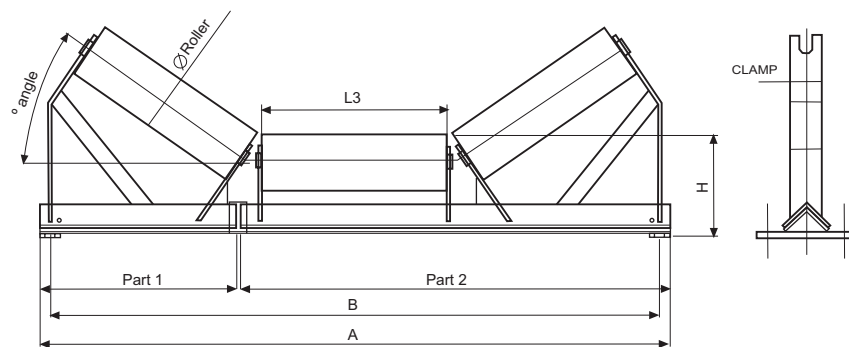

ADJUSTABLE

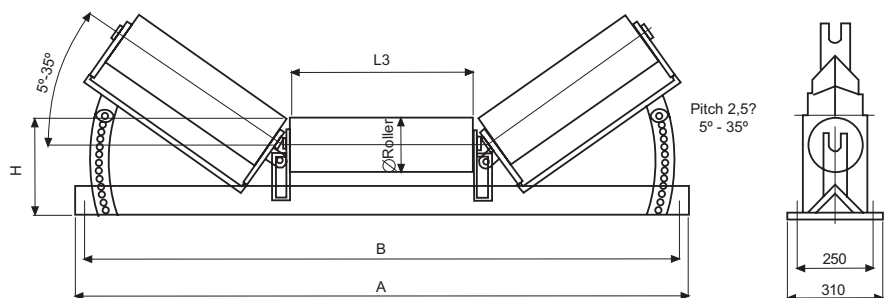

# IDLER

**BOTTOM FLAT, BRACKET**

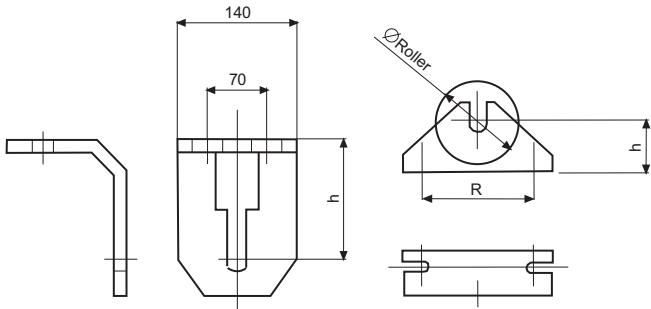

**BOTTOM FLAT WITH BASE**

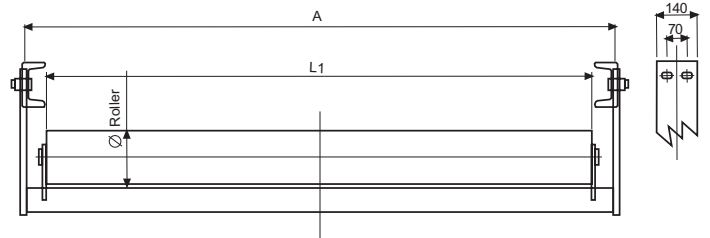

**BOTTOM V SHAPED**

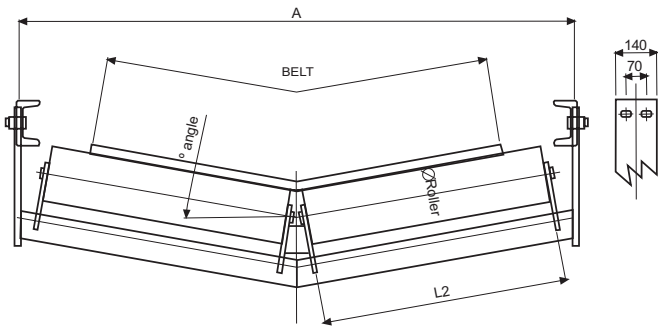

**BOTTOM INVERTED V**

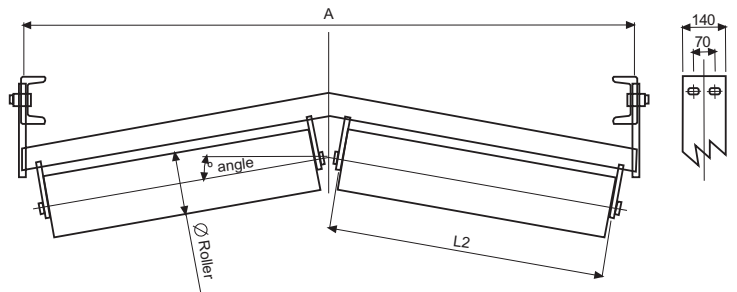

**BOTTOM SELF-ALIGNING FLAT**

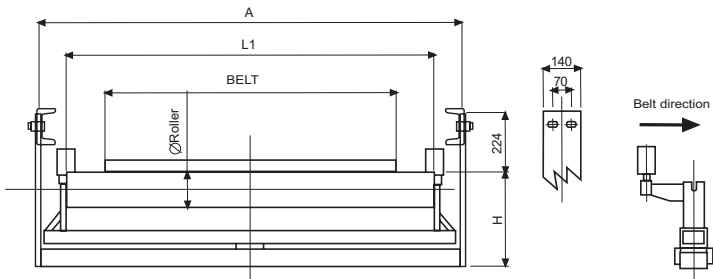

**BOTTOM SELF-ALIGNING V SHAPED**

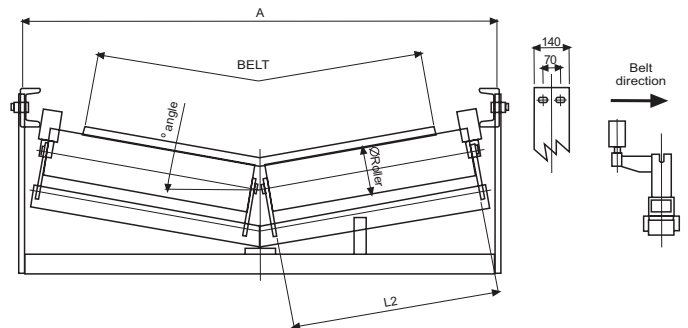

**LOW**

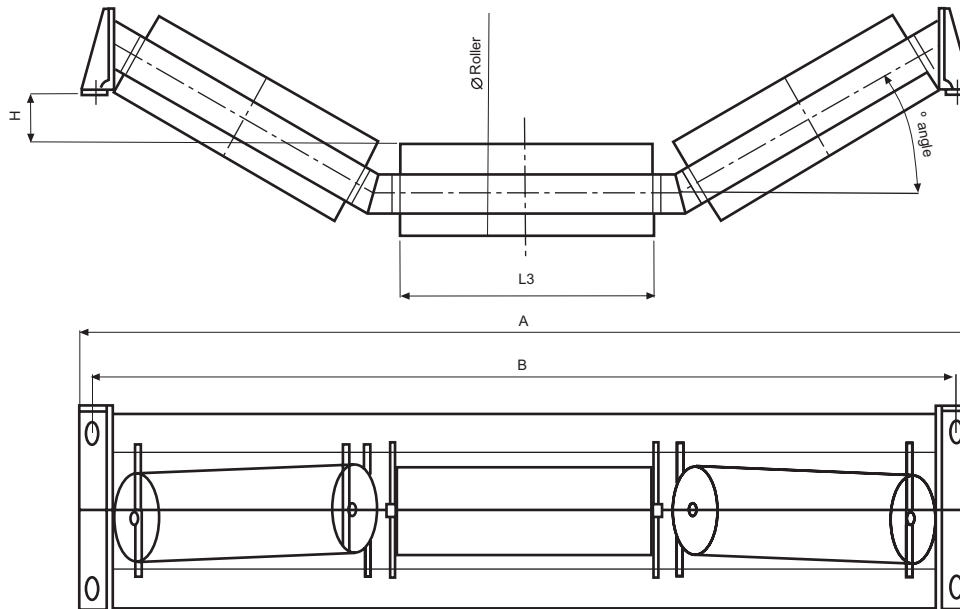

# IDLER FRAMES

DESIGN ACCORDING TO DIN22107 / ISO 1537 STANDARDS							
Belt	A	B	Ø Roller	H	L1	L2	L3
400	700	650	63,5	62	500	250	160
			89	75			
			108	85			
500	800	750	63,5	62	600	315	200
			89	75			
			108	85			
			133	100			
650	950	900	63,5	62	750	380	250
			89	75			
			108	85			
			133	100			
800	1150	1100	89	75	950	465	315
			108	85			
			133	100			
1000	1350	1300	89	75	1150	600	380
			108	85			
			133	100			
			159	130			
1200	1600	1550	108	85	1400	700	465
			133	100			
			159	130			
1400	1800	1750	133	100	1600	800	530
			159	130			
1600	2050	2000	133	100	1800	900	600
			159	130			
1800	2250	2200	133	100	2000	1000	670
			159	130			
			194	160			
2000	2500	2450	159	130	2200	1100	750
			194	160			
2200	2700	2650	159	130	2500	1250	800
			194	160			
2400	2950	2900	159	130	2800	1400	900
			194	160			
2600	3150	3100	159	130	3000	1500	950
			194	160			
2800	3400	3350	159	130	3150	1600	1050
			194	160			
			219	180			
3000	3600	3550	159	130	3350	1700	1120
			194	160			
			219	180			

\*L1: length of the roller in a one roller idler frame.  
L2: length of the roller in a two roller idler frame.  
L3: length of the roller in a three roller idler frame.

# IDLER FRAMES

DESIGN ACCORDING TO CEMA B STANDARDS							
Belt	A	B	Ø Roller	H	L1	L2	L3
14	25	23	4	7,19	16,75	-	5,25
			5	7,69			
16	27	25	4	7,19	18,75	-	5,88
			5	7,69			
18	29	27	4	7,19	20,75	-	6,62
			5	7,69			
20	31	29	4	7,19	22,75	-	7,25
			5	7,69			
24	35	33	4	7,19	26,75	-	8,62
			5	7,69			
30	41	39	4	7,19	32,75	-	10,62
			5	7,69			
36	47	45	4	7,19	38,75	-	12,62
			5	7,69			
42	53	51	4	7,19	44,75	-	14,62
			5	7,69			

Measurements in inches

\*L1: length of the roller in a one roller idler frame.  
 L2: length of the roller in a two roller idler frame.  
 L3: length of the roller in a three roller idler frame.

DESIGN ACCORDING TO CEMA C STANDARDS							
Belt	A	B	Ø Roller	H	L1	L2	L3
18	29	27	5	8,25	20,62	6,62	6,69
			6	8,75			
20	31	29	5	8,25	22,62	9,62	7,44
			6	8,75			
24	35	33	5	8,25	26,62	12,81	8,81
			6	8,75			
30	41	39	5	8,62	32,62	16	10,81
			6	9,12			
36	47	45	5	8,62	38,62	19,19	12,81
			6	9,12			
42	53	51	5	9	44,62	22,62	15,12
			6	9,5			
48	59	57	5	9	50,62	25,62	17,12
			6	9,5			
54	65	63	5	9	56,62	28,62	19,19
			6	9,5			
60	71	69	5	9	62,62	31,62	21,19
			6	9,5			

Measurements in inches

\*L1: length of the roller in a one roller idler frame.  
 L2: length of the roller in a two roller idler frame.  
 L3: length of the roller in a three roller idler frame.

# IDLER FRAMES

DESIGN ACCORDING TO CEMA D STANDARDS							
Belt	A	B	Ø Roller	H	L1	L2	L3
18	29	27	5	8,25	20,81	6,75	6,62
			6	8,75			
20	31	29	5	8,25	22,81	9,75	7,34
			6	8,75			
24	35	33	5	8,25	26,81	12,75	8,75
			6	8,75			
30	41	39	5	8,62	32,81	15,94	10,75
			6	9,12			
36	47	45	5	8,62	38,81	19,12	12,75
			6	9,12			
42	53	51	5	9	44,81	22,81	15,06
			6	9,5			
48	59	57	5	9	50,81	25,81	17,06
			6	9,5			
54	65	63	5	9	56,81	28,81	19,12
			6	9,5			
60	71	69	5	9	62,81	31,81	21,12
			6	9,5			
66	77	75	5	9,38	68,81	34,81	23,12
			6	9,38			
72	83	81	5	9,38	74,81	37,81	25,12
			6	9,38			

Measurements in inches

\*L1: length of the roller in a one roller idler frame.  
 L2: length of the roller in a two roller idler frame.  
 L3: length of the roller in a three roller idler frame.

DESIGN ACCORDING TO CEMA E STANDARDS							
Belt	A	B	Ø Roller	H	L1	L2	L3
36	50	45	6	10,44	39,88	19,62	13,56
			7	10,94			
42	56	51	6	10,44	45,88	22,62	15,56
			7	10,94			
48	62	57	6	10,44	51,88	25,56	17,56
			7	10,94			
54	68	63	6	10,44	57,88	29,25	19,62
			7	10,94			
60	74	69	6	10,44	63,88	31,56	21,38
			7	10,94			
72	86	81	6	11,12	75,88	37,56	25,25
			7	11,62			
84	98	93	6	11,88	87,88	43,88	29,25
			7	12,38			
96	110	105	6	11,88	98,88	49,88	33,25
			7	12,38			

Measurements in inches

\*L1: length of the roller in a one roller idler frame.  
 L2: length of the roller in a two roller idler frame.  
 L3: length of the roller in a three roller idler frame.

# IDLER

DESIGN ACCORDING TO CEMA F							
Belt	A	B	Ø Roller	H	L1	L2	L3
48	62	57	7	12,31	51,56	25,56	17,75
			8	12,81			
54	68	63	7	12,31	57,56	29,25	19,88
			8	12,81			
60	74	69	7	12,31	63,56	31,56	22
			8	12,81			
66	80	75	7	12,31	69,56	34,56	24,12
			8	12,81			
72	86	81	7	12,31	75,56	37,56	26,25
			8	12,81			
78	92	87	7	12,31	81,56	40,56	28,38
			8	12,81			
84	98	93	7	13	87,56	43,88	30,5
			8	13,5			
96	110	10	7	13	99,56	49,88	34,75
			8	13,5			
10	12	5	7	13,06	111,56	54,88	39
			8	13,56			
8	2	117	7	13,06	123,5	60,88	43,25
			8	13,56			

Measurements in inches

\*L1: length of the roller in a one roller idler frame.  
 L2: length of the roller in a two roller idler frame.  
 L3: length of the roller in a three roller idler frame.